



TEMPERATURE CONTROLLER

EC4100C

Compact and Easy Operation

High Reliability and Performance



Features

- Selectable Input (Thermocouple/RTD or Voltage/ Current)
- Auto-Tuning, Self-Tuning Provided as Standard
- 2 Alarm/Output (Option)
- RS-485 Communication Interface (Option)
- CT input, DI (Option)

■ SPECIFICATIONS

Power Supply Voltage	100 to 240V AC, 50/60 Hz
Power Consumption	Less than 10 VA
Memory Element	EEPROM
Input of Sensor	Thermocouple, R.T.D./0-5V, 1-5V, 4-20mA (Changeable by key)
Control Output	Relay contact/SSR drive voltage/Current 4-20mADC
Control Method	Two kinds of PID, ON/OFF
Operation Environment	0 to 50°C, 20 to 90%RH(Avoid making dew)
Storage Environment	-25 to 70°C, 5 to 95%RH(Avoid making dew)
Weight	Less than 180g
Location of the Unit Setting	Keep away from the followings. · Gas of corrosion, dust and oily smoke. · The electric noise of generator. · The influence of electromagnetic field. · Mechanical vibration and shock. · The direct sunshine.
Installation condition	Installation category II Pollution degree 2(EN61010-1)

■ MODEL CODE NUMBER

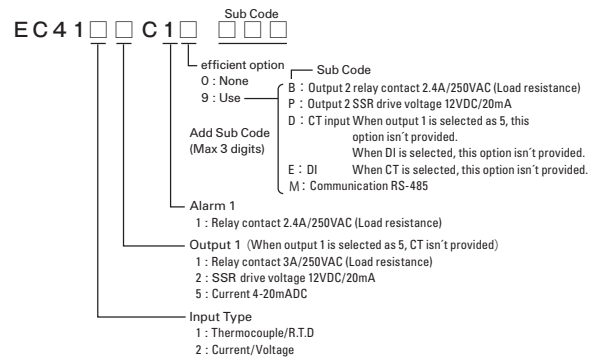

■ PARTS INDICATION

PV	Process variable, character for setting mode display.	COM	Flash ON and OFF when communicating. Lights ON when communication is selected as an option.	
SP	Set point, input value for setting mode display.	RDY	Lights ON under Ready.	
OUT1	Lights ON when output 1 turn ON.	DI	Lights ON when DI turn ON.	
OUT2	Lights ON when output 2 turn ON.	key	For change of display.	
ALM1	Lights ON when Alarm output 1 turn ON.	FUNC key	For action of function setting.	
ALM2	Lights ON when Alarm output 2 turn ON.	key	Up down key for change of set point. Holding the up down keys are the value at a rapid rate.	

■ DIMENSIONS

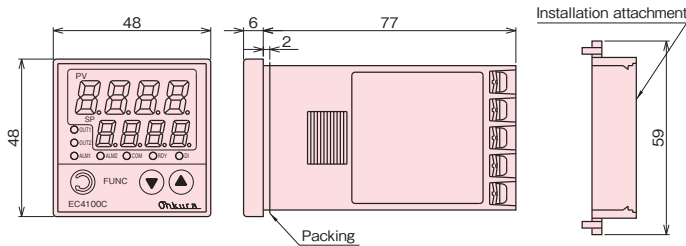

■ PANEL CUTTING DIMENSIONS

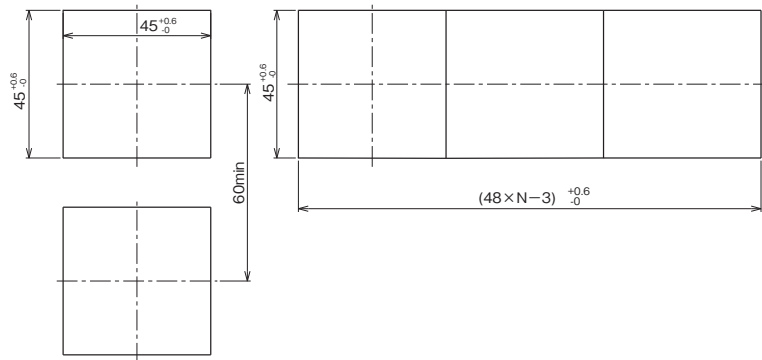

■ WIRING

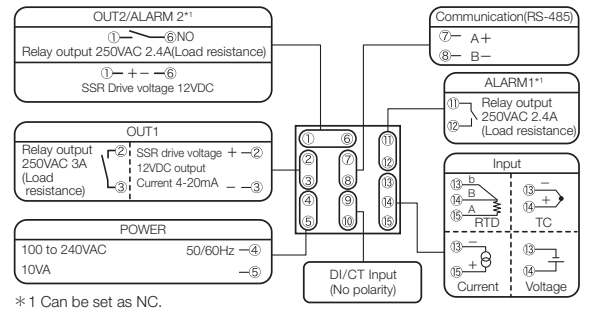

CAUTION

Do not install this device before consulting instruction manual



OHKURA ELECTRIC CO., LTD.
 Head Office / Factory Saitama, JAPAN
 Sales Offices Tokyo, Osaka, Nagoya, Kyushu,
 URL <http://www.ohkura.co.jp/>
 e-mail (in English) contact_e@ohkura.co.jp

Specifications are subject to change without notice.
 For further information, a quotation or a demonstration please contact to: